

KATIE TABLE LOOM

A folding 8 shaft 30cm (12ins) table loom

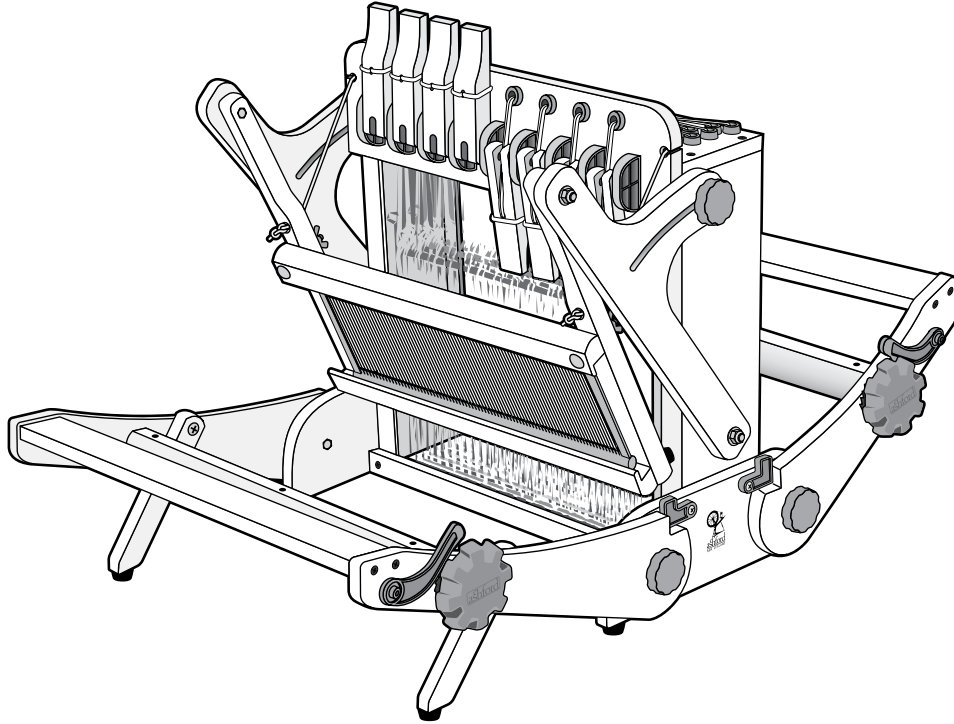

Dear Weaver,

Congratulations on purchasing your new Katie Table Loom. For over 75 years we have been making craft equipment for spinners and weavers around the world and have now produced over 600,000 wheels and looms. We are sure you will enjoy the convenience and portability of this loom. Thank you for choosing Ashford.

Your Katie Table Loom has been lacquered prior to assembly. If desired, an application of Ashford Wax finish may further enhance its appearance.

To unfold your loom

Step 1: Loosen the knobs securing the front beam and fold down.

Engage the locks, lift the front beam and tighten the knobs.

Step 2: Lift the front of the loom slightly and fold the feet out.

Step 3: Loosen the knobs securing the back beam and fold down.

Engage the locks, lift the back beam and tighten the knobs.

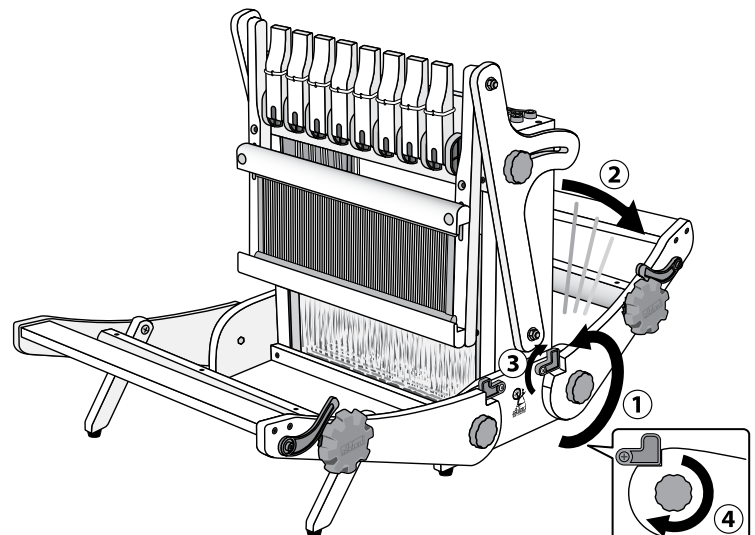
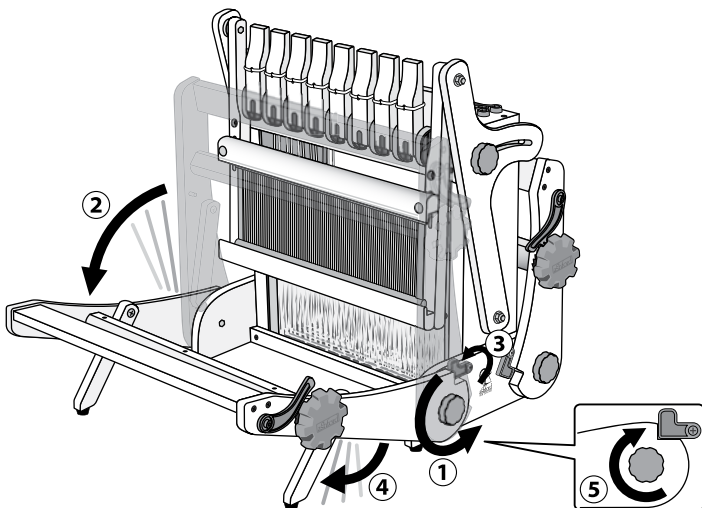

Step 4: Loosen knobs securing the beater supports, slide the beater completely forward and tighten the knobs.

Step 5: Tie a knot in the ends of the bungee cords and thread them through the holes in the beaters. Tie a knot in the other end and locate them into the slots in the castle front. Adjust the position of the knot to increase or decrease the tension.

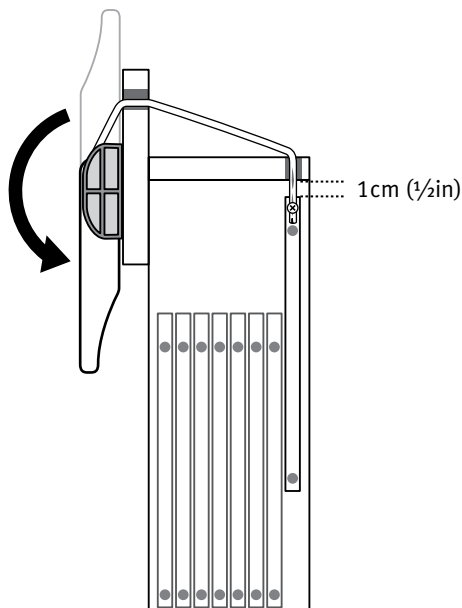
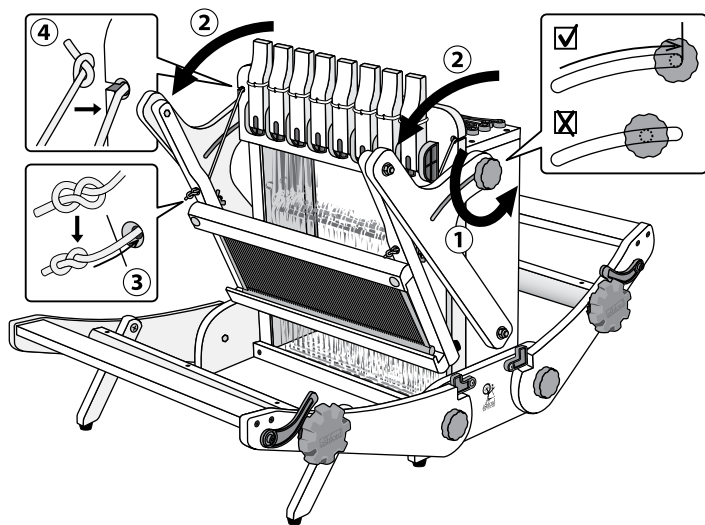

Step 6: Push the levers down and check the gap between the shafts and the castle top is approx. 1cm (1/2ins) on both sides. Adjust the height as necessary by moving the Texsol cord in the lever or on the screw head in the shaft end.

Step 7: Attach the front and back warp sticks with the cotton string supplied with your loom as illustrated.

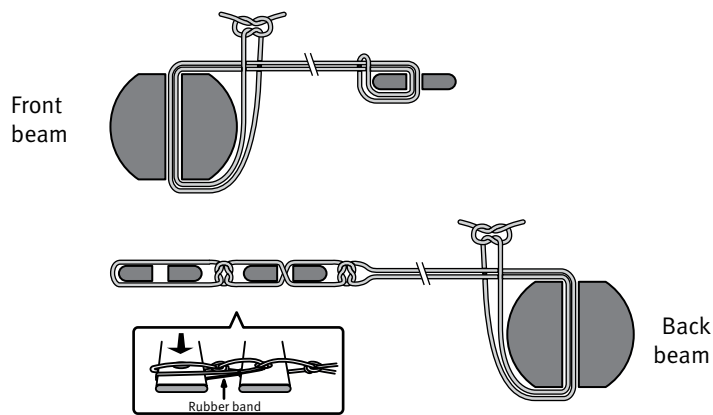

Step 8: To fold the loom, lift all the levers and reverse steps 4, 3, 2 and 1.

Warping Instructions: Refer to the Learn To Weave on the Table Loom Booklet. Please note the weaving project in the booklet is for a project on a 40cm (16ins) four shaft loom. For a project on the Katie Table Loom please start with the project notes enclosed.

IMPORTANT

When you need to advance your weaving, only advance it so the fell (the edge of the weaving at the last weft pick) is level with the legs. If you advance it too far your beater will hit the bottom roller.

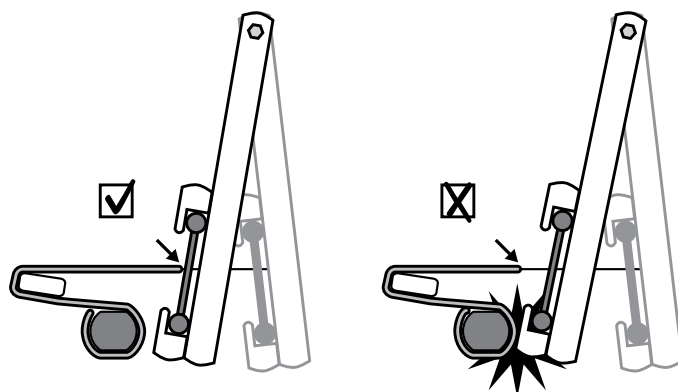

Recommended Accessories:

- Raddle Kit 30cm (12ins)
- Warping Frame – either 11m (37ft) or 4m (14ft)

Other Accessories:

- Boat Shuttle 29cm (11ins), Boat Shuttle 35cm (14ins)
- Boat Shuttle Bobbin Winders Wood and Metal
- Stick Shuttles
- Stainless Steel Reeds - 6, 8, 10, 12 and 16 DPI
- Texsol Heddles - Bundles of 40 or 100

Recommended Reading:

- The Ashford Book of Four Shaft Weaving by Anne Field.
- The Ashford Book of Projects for the Eight Shaft Loom by Elsa Krogh.

Happy Weaving!

KTL09022012V2