

ASHFORD INKLETTE LOOM

A PORTABLE INKLE LOOM

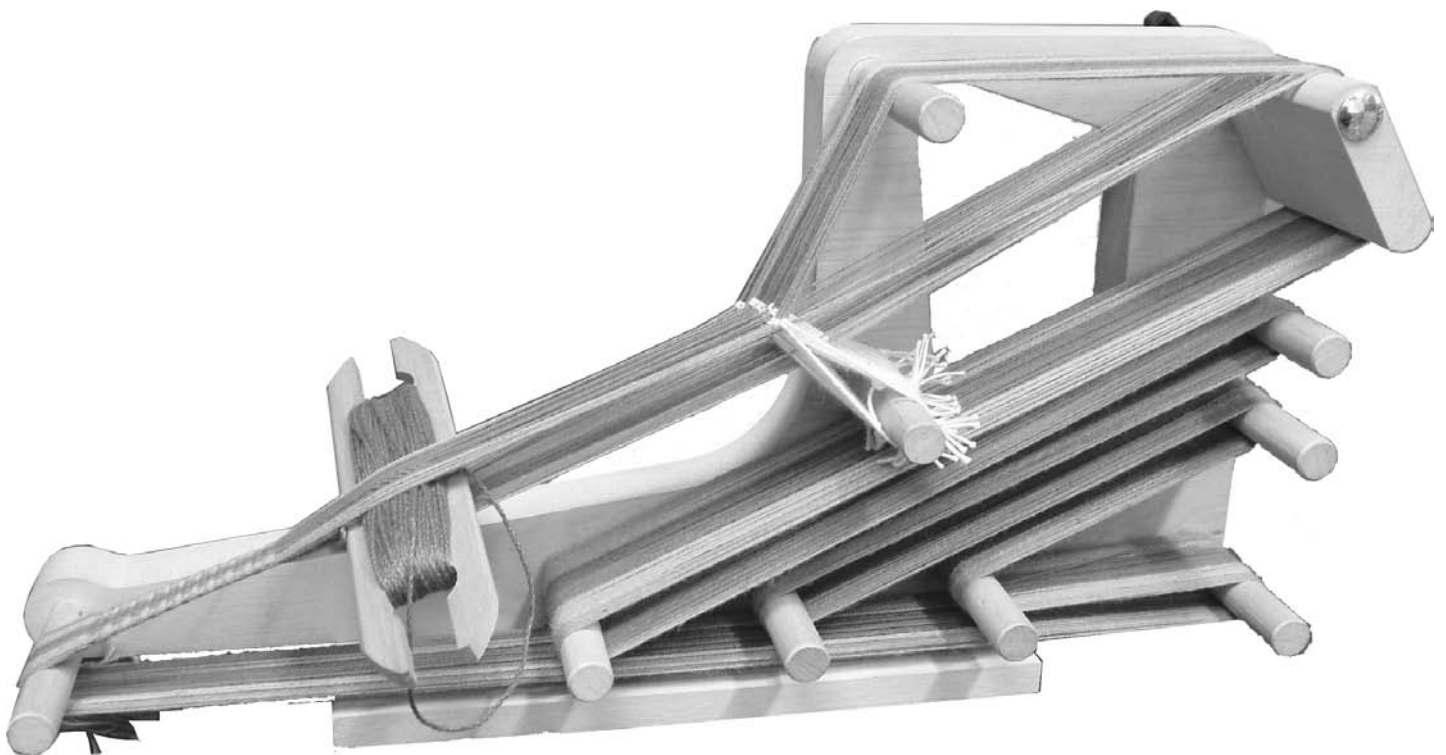

IKL13022012V3

Weave your own colourful belts, bracelets, hand bag and guitar straps, necklaces, ties and braids

Amazing 72", 1.8m warp

Lightweight portable and strong

Take it with you to workshops,
meetings or on holiday!

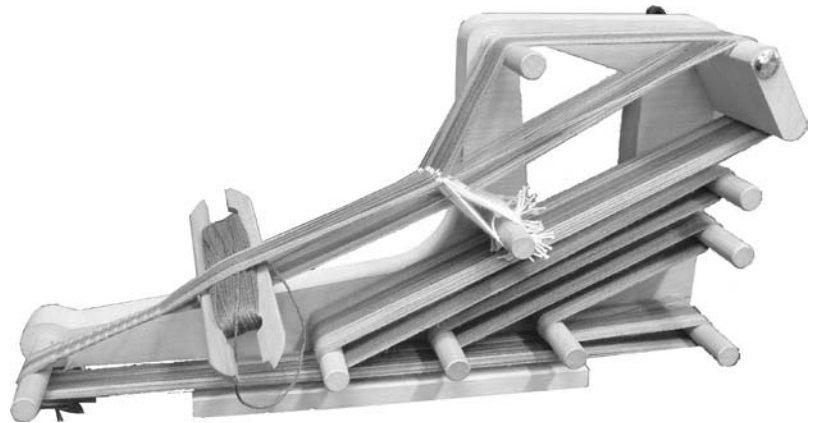

TOOLS REQUIRED

Hammer, screwdriver, candlewax (for screw threads) and glue (included).

ASSEMBLY

- 1) Use the sandpaper provided to remove any sharp edges and to smooth the pegs.
- 2) Place the side on a firm work bench. Then check the peg is an easy fit in the hole, if tight use the sandpaper to help make peg a nice fit. Carefully smear a little glue in one hole. Too much glue may cause the wood to split! Carefully tap the peg into the hole. Wipe any excess glue away with a damp cloth. Do this again with each peg. It is best to do each peg, one at a time.
- 3) Attach the base to the side with 2 screws.
- 4) Locate the bolt in the hole in the tension flap and tap the head into the wood.
- 5) Locate the bolt through the side and secure with the washer and nylon knob.
- 6) Please allow 4 hours for the glue to harden.

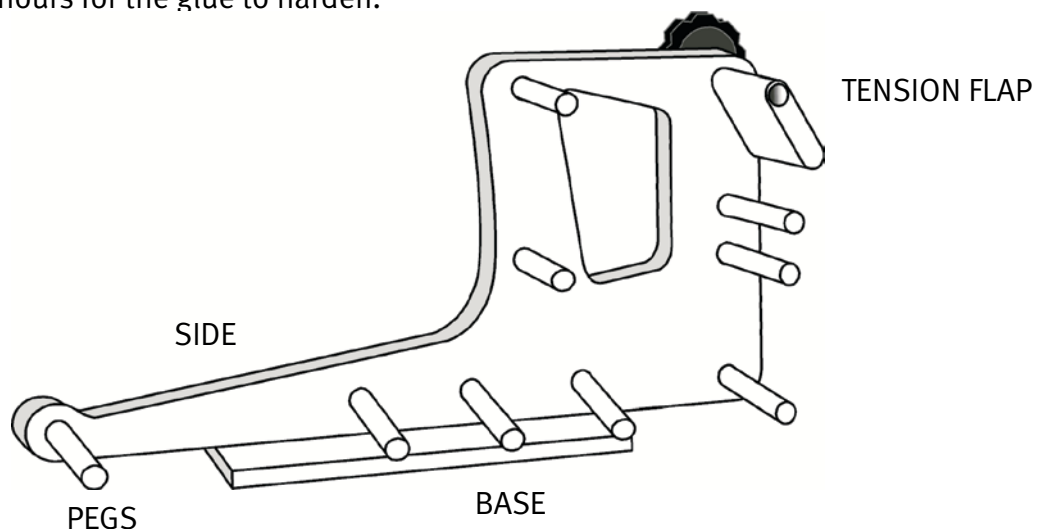

WARPING AND WEAVING INSTRUCTIONS

WARP LENGTH: 1.8m - 72"

MAX WARP WIDTH: 40mm - 1 1/2"

INKLE BANDS These colourful bands are very strong and have many uses. They make belts, ties, guitar straps, braiding for homespun's and trims for joining pieces of weaving. They have a dominant warp face, ie the warp threads show. The weft thread is not visible except at the selvedge.

THREADS TO USE Use strong, smooth and colourful threads. Mercerised cotton is good. Most wool is suitable but avoid wool that is soft or hairy. (These tend to cling to each other and make it difficult to obtain a clean open shed). Textured and metallic threads, silk and nylon add variety. Be experimental, but make sure all threads have about the same amount of elasticity, otherwise the surface will be uneven.

WIDTH OF WARP Because the weft thread is pulled tight, the inkle band will be reduced to about half the original width of the warp. However, if you want to increase or decrease the width at any stage, this is done by the amount of tension on the weft thread.

SHUTTLE A shuttle with a sharp edge for beating is included in the kit.

TENSION FLAP This flap is used to keep the warp under tension when weaving. When moving the weaving around the loom, loosen the flap to release the tension. Use two hands to advance the warp. When using a full length warp take care to move the weaving little by little. Do not pull too tight, you could break a peg!

FINISHING THE FRINGE Darn in the last weft thread. Warp ends may be tied in small overhand knots. Using both hands, twist the bundles of threads to the right, between thumb and finger, then wrap these twisted threads together in opposite direction. The inkle band fringe may also be finished by twisting or braiding.

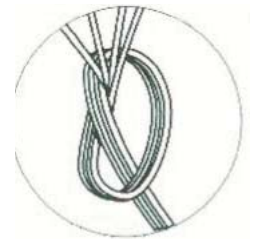

WARPING THE LOOM

- Choose the length of inkle band you want, from the short warp to long warp.
- Set the position of the tension flap prior to warping as illustrated.
- Tie the warp thread to the front peg with a temporary knot
- Colour change. Always tie the last thread to the next thread at the front peg.

Start and change colours here →

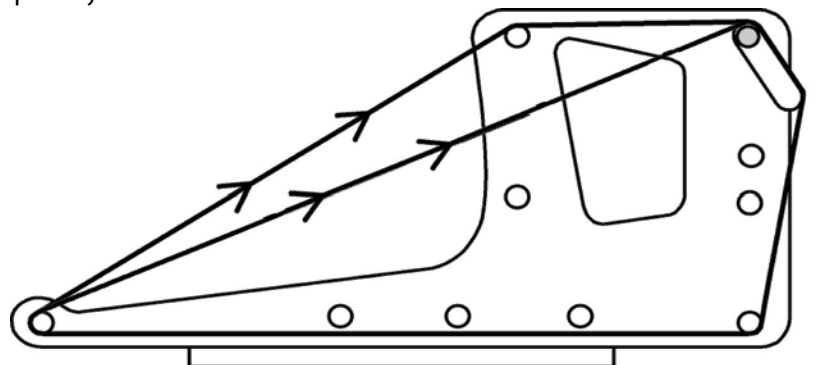

NOTE:

When using thick or non-stretchy yarns, the warp will be easier to move if you do not use all the pegs.

LONG WARP

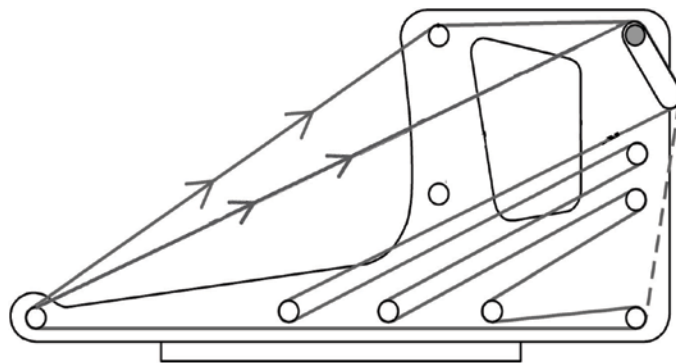

ROUND 1

- Take the warp thread directly to the tension flap as illustrated.

ROUND 2

- Take the warp thread over the top peg and over the tension flap.

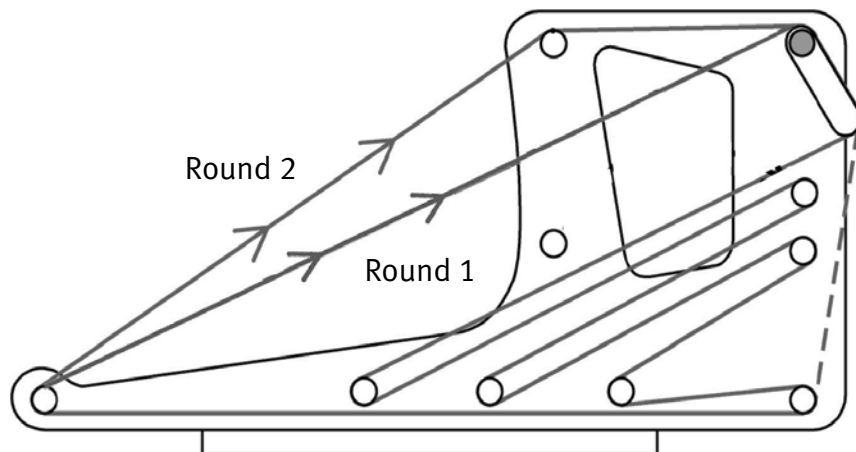

Repeat Round 1 and Round 2 until the desired warp width is achieved. If you have a multicoloured warp, add one extra Round 1. Also, tie the first thread of the new colour to the last thread maintaining the same tension as the rest of the warp. On wider warps cut and tie when you change colours.

MAKING THE LEASHES

Use string or fine strong cotton. Wind the string around the two leash pegs as shown.

Cut the string as shown.

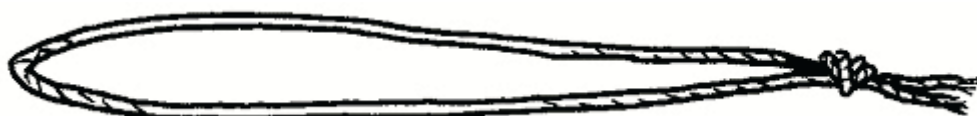
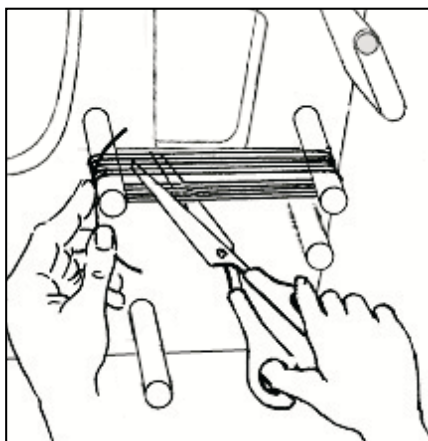

Fold each leash in half and tie a knot 1cm (3/8") from the end.

Attach a leash to all the top threads between each open (centre) thread.

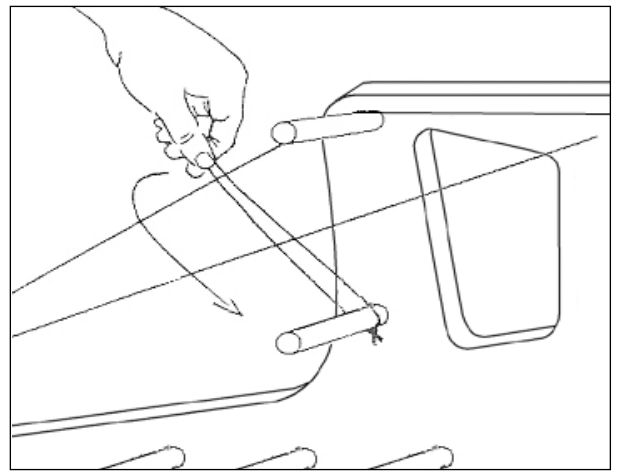
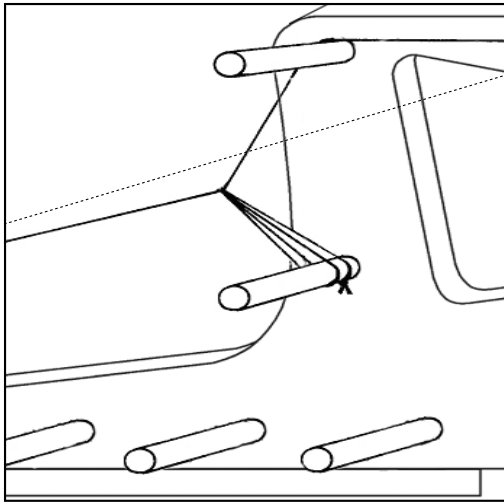

Keep the knot for the leash under each leash peg.

MAKING THE SHED

The shed is the space between the two layers of warp and is obtained by the use of leashes.

A thread NOT going through a leash is called an “open” thread.

Shed 1 Is made by lifting all the open threads

Shed 2 Is made by pushing down all the open threads

CHANGING SHEDS

To get the best shed, push down or lift up the threads with your fingers close behind the leashes.

SHED 1

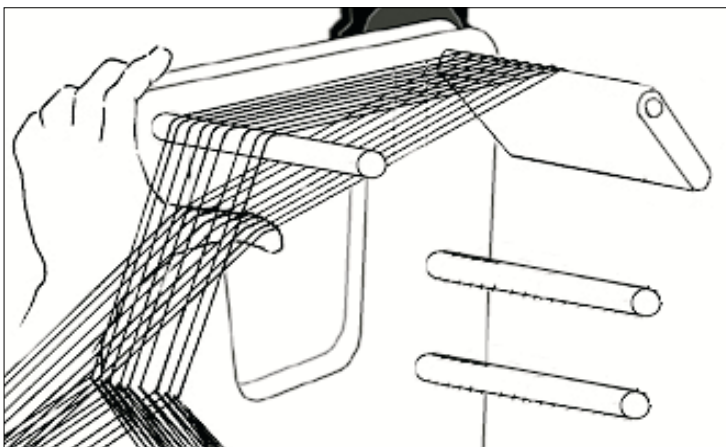

SHED 2

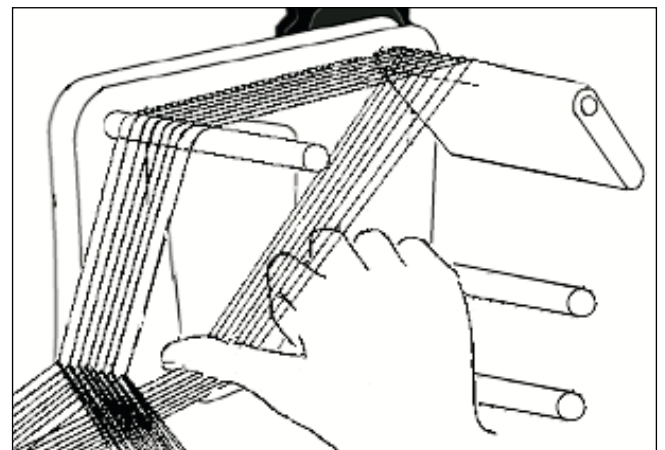

SHUTTLE

Wind the weft thread onto the shuttle which is usually the same colour as the edge threads.

WEAVING

Make Shed 1. Pass the shuttle into the space between the threads. Pull the shuttle firmly down towards the front peg. Pull the shuttle out of the shed - pull the weft thread tightly. The weft threads will move together closely so you cannot see the weft at all through the warp.

- Make shed 2 and repeat.

- Use the sharp edge of the shuttle to beat each row firmly into place.

KEEPING THE EDGES STRAIGHT

The first 2-3cm usually look poor because the tension isn't right yet, and you may have some crossed threads. Don't worry! This part can be unravelled when the finished braid is cut off the loom.

From now on though, it's possible to keep the edges beautifully straight by following simple rules:

- 1) Keep the warp very tight. A high tension makes the whole braid and edges look better when finished.
- 2) Try to keep the same tension on the weft as well. Make it quite tight so that the warp threads sit on top of each other.
- 3) Everytime you pull the shuttle out of the shed, and before you tighten the weft, pull the previous weft thread again. That will even out the little loop that occurs between the two outer warp threads, which is essential when it comes to making even edges.

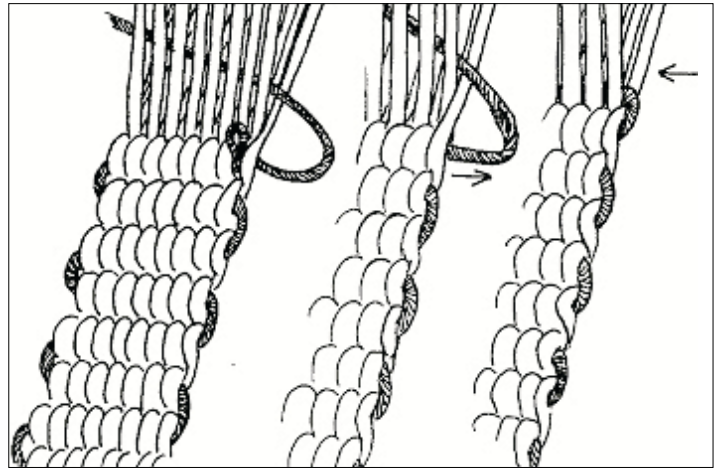

MOVING THE WARP

Loosen the nylon knob and move the tension flap down. The warp will slacken. Pull the warp forwards towards yourself until the end of the woven piece is about 5cm, 2" from the front peg. Gradually move all the threads around from peg to peg! TAKE CARE when you are using the longest warp length! Do not pull too tight, you could break a peg! Tighten the tension flap. PUSH the leashes back to their correct position.

FINISHING

When you can't move the warp any further and the knots in the warp are close to the leashes, simply cut each half of the warp 3cm, 1 1/2" behind the leashes and pull the threads out.

Sew the weft back three or four rows to lock it. Now the warp threads cannot come undone unless you cut it very close to the end of the braid. So, don't do that!

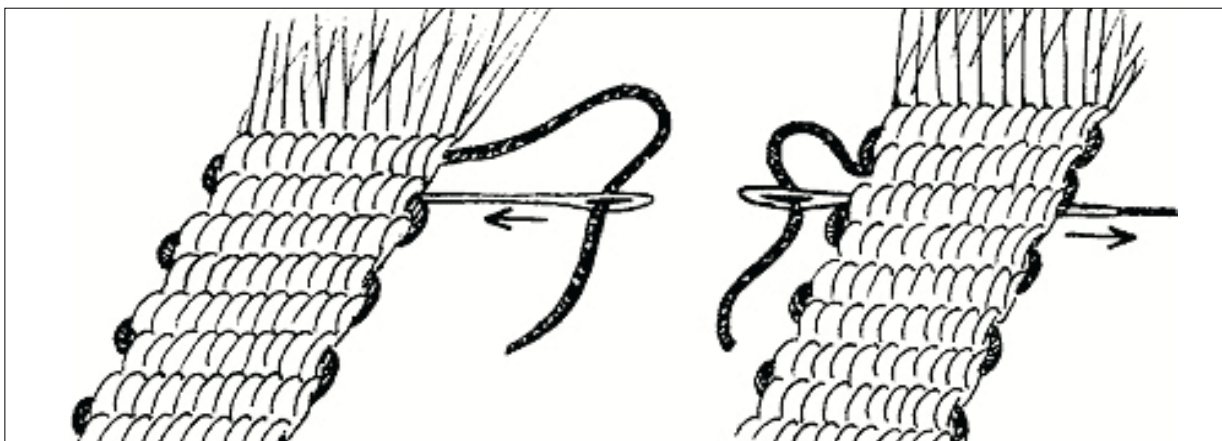

Let the ends hang loose as a fringe, plait, twist, tie knots, glue and cut close to the braid so you can fold the end of it under, or tie the ends around a piece of wood to make a wall-hanging.

PROJECTS

NO. 1 INKLE BAND

This is a good starter project.
Make your first project a short warp.

Stripes of different colours and an area of alternating colours create a pattern that will teach you how warp-faced patterns work.

Use colours of high contrast to make the pattern stand out.

Use 5/2 or 10/2 cotton or size 5 or 10 crochet cotton.
When you have finished your first pieces, try a 20/2 or 30/2 silk for a fine band with a beautiful sheen.

This pattern has 49 ends and will require 24 leashes.
To help the threading there is a line dividing each colour group.
X and O are different colours. You can do just 2 colours or a different colour in each group.
Join the ends when changing colours as you make the warp.

TOP LEASH/THREAD	X X O O X X O O O O O O X X O O O O O X X O O X X
OPEN LOWER/THREAD	X X O O X X X X X O O X X X O O X X X X X O O X X

CENTRE THREAD

Use the same colour at the selvedge and for your weft. This will allow the weft to blend in.
To make a heavier band use a thicker thread for the weft.

NO. 2 WEAVING WITH WIRE. A BRACELET

This is a fun way to try something really different on your little Inklette.
Use 26 gauge craft wire and warp around the circumference of the outer pegs.
This is the short warp shown in the warping instructions.

Make a warp with 17 ends. This pattern will require 8 leashes.
Weave with the same wire.
It will feel very stiff after weaving with cotton.

Weave for approx 20cm (8 inches)
Cut the ends using a pair of wire cutters (non-jewellery)

Use a pair of nylon jaw pliers (sometimes called "soft-jawed") to fold over the ends.
Allow a good grip when folding the ends over without damaging the surface of the wire.
The Bracelet will bend into place around your wrist.